

2002

Caravanes pliantes toile  
Trailer tents  
Vouwwagens  
Zeltanhänger  
Remolques de campaña  
Carrelli tenda tela

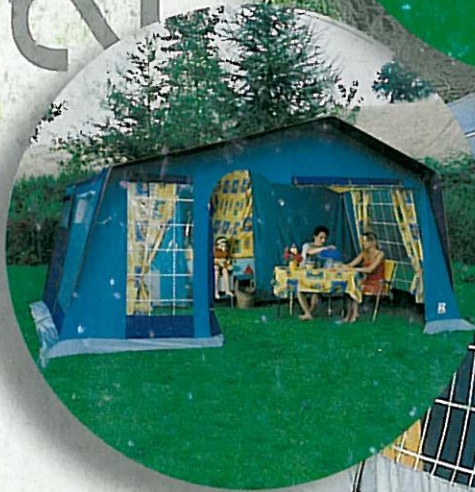

Caravanes Pliantes

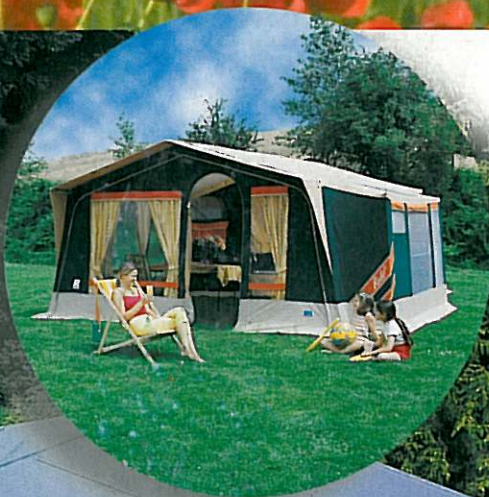

# Minto®



## 200 Kg

Poids à vide  
Weight (excl. baggage)  
Eigengewicht  
Leergewicht  
P.A.V  
Peso proprio

## 450 Kg

Poids total en charge  
Maximum loaded weight  
Max. toelaatbaar gewicht  
Max. Gesamtgewicht  
P.A.P.C.  
Peso total



16.5 x 6.5-B

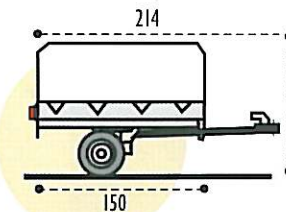
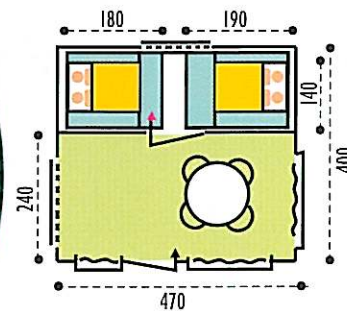
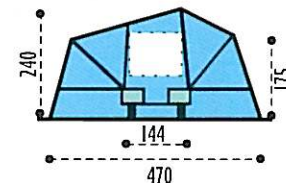



# Minto®





# Iris

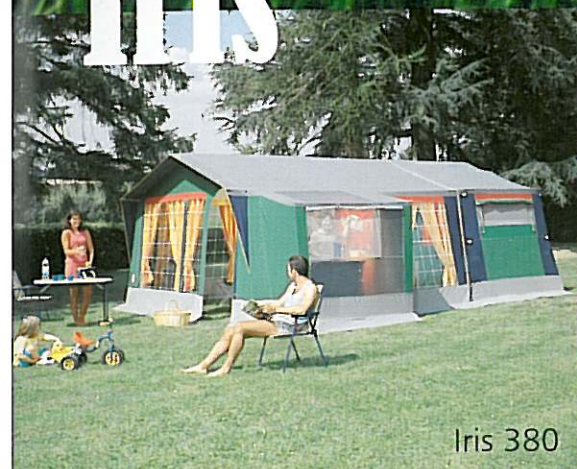

Iris 380

**ARMA  
Clic®**  
Iris Luxe



Option

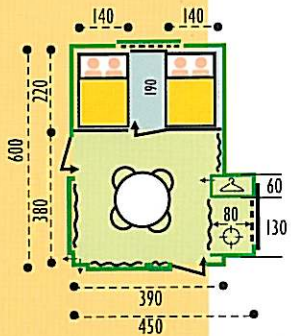

Iris 380

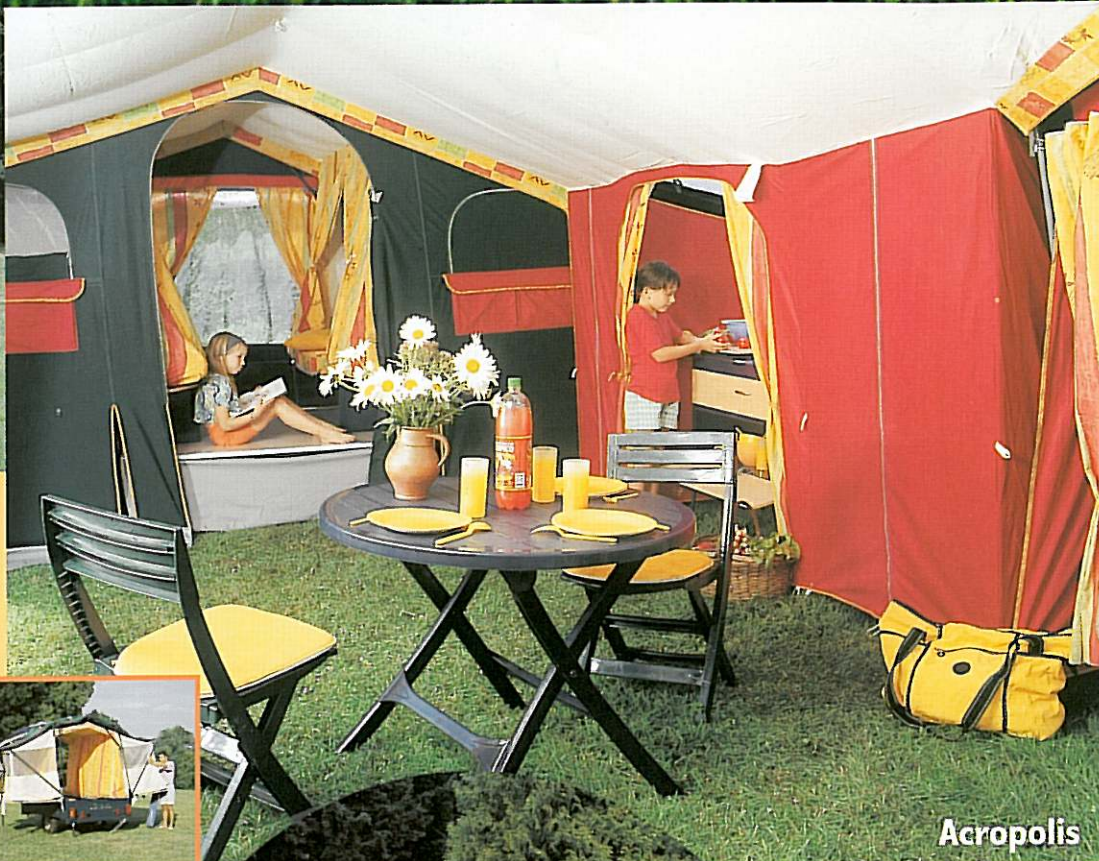

Acropolis

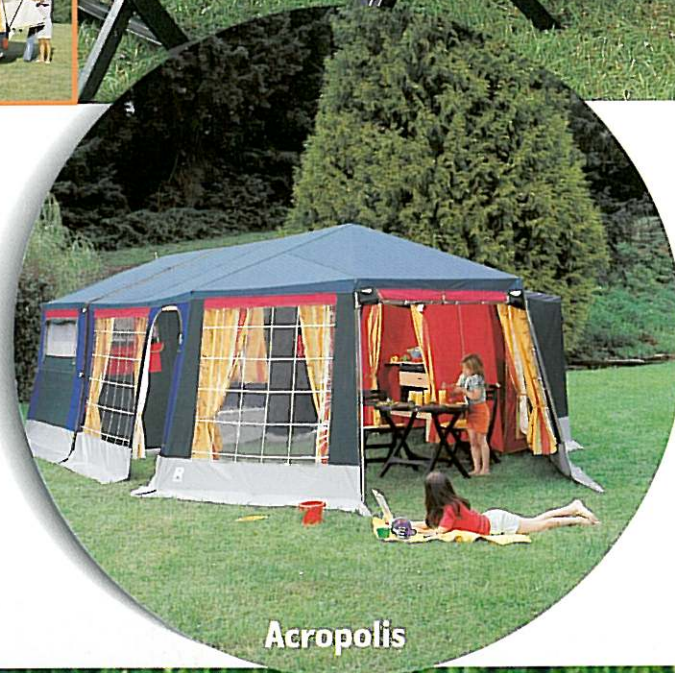

Acropolis

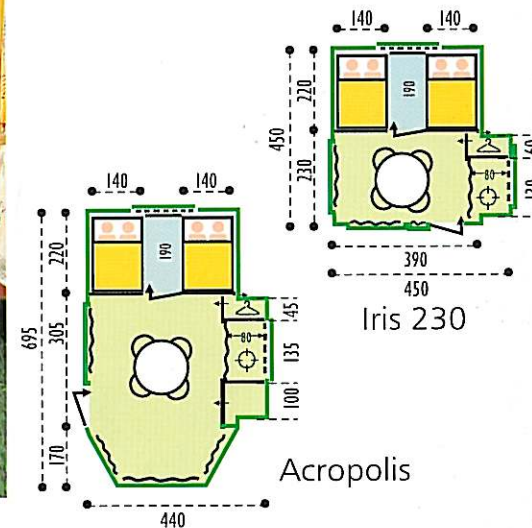

Iris 230

Acropolis

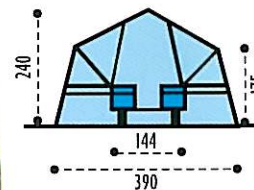

500 x 10

**310 Kg / 340 kg**

Poids à vide  
Weight (excl. baggage)  
Eigengewicht  
Leergewicht  
P.A.V.  
Peso propio

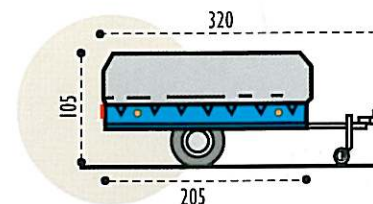

**495 Kg - 650 Kg (NL)**

Poids total en charge  
Maximum loaded weight  
Max. toelaatbaar gewicht  
Max. Gesamtgewicht  
P.A.P.C.  
Peso total



# Iris



**RACLET**

*Caravanes Pliantes*



Iris 230 : Sprinter  
Iris 380 : Marathon



Iris 230



# Cortina®

# Borneo



**350 Kg**

Poids à vide  
Weight (excl. baggage)  
Eigengewicht  
Leergewicht  
P.A.V.  
Peso proprio



500 x 10

**495 Kg**

Poids total en charge  
Maximum loaded weight  
Max. toelaatbaar gewicht  
Max. Gesamtgewicht  
P.A.P.C.  
Peso total



**375 Kg**  
Poids à vide  
Weight (excl. baggage)  
Eigengewicht  
Leergewicht  
P.A.V.  
Peso proprio



500 x 10

**495 Kg - 650 Kg (NL)**  
Poids total en charge  
Maximum loaded weight  
Max. toelaatbaar gewicht  
Max. Gesamtgewicht  
P.A.P.C.  
Peso total

Essieu freiné  
Axle with brake  
Oploeprem  
Achse mit Bremsvorrichtung  
Assle con freno  
Eje con freno



135x13

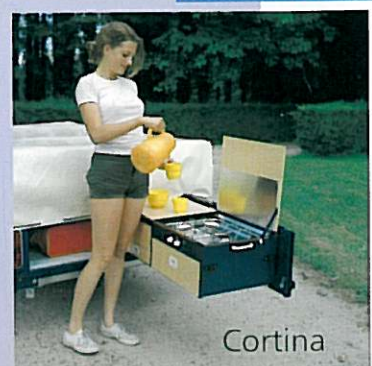
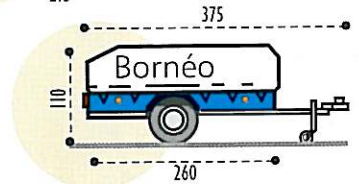
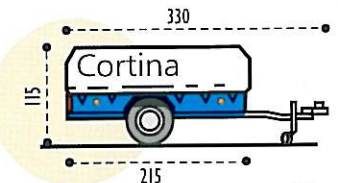
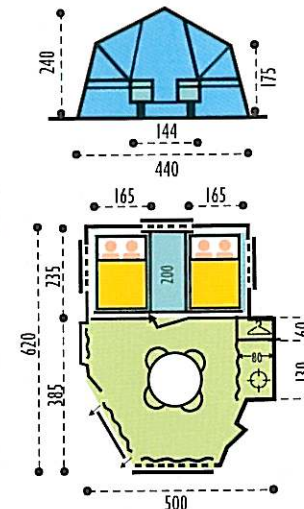

Cortina



# Cortina®

Residentiel



RAGLET



Cortina - Tribune



Cortina





# Bermudes®



**350 Kg** Poids à vide  
Weight (excl. baggage)  
Eigengewicht  
Leergewicht  
P.A.V.  
Peso proprio



500 x 10

**495 Kg** Poids total en charge  
Maximum loaded weight  
Max. toelaatbaar gewicht  
Max. Gesamtgewicht  
P.A.P.C.  
Peso total



# Batik®



**375 Kg** Poids à vide  
Weight (excl. baggage)  
Eigengewicht  
Leergewicht  
P.A.V.  
Peso proprio



500 x 10

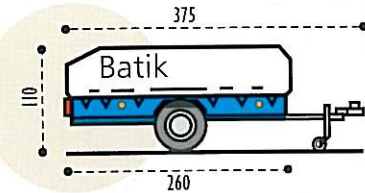

**495 Kg - 650 Kg (NL)** Poids total en charge  
Maximum loaded weight  
Max. toelaatbaar gewicht  
Max. Gesamtgewicht  
P.A.P.C.  
Peso total



135x13

Essieu freiné  
Axle with brake  
Oplooptrem  
Achse mit Bremsvorrichtung  
Assle con freno  
Eje con freno

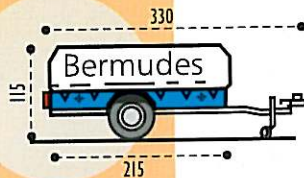
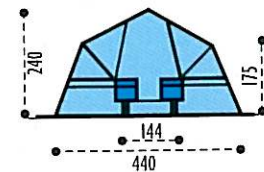
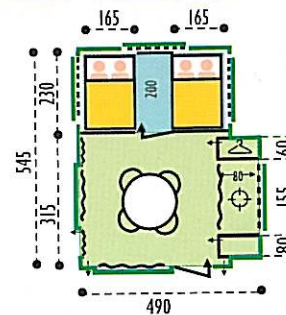

**ARMA**  
**Clic®**

**up two**  
Bermudes



# Bermudes®



**RACLET**  
*Caravanes Pliantes*



Résidentiel



**RACLET**  
*Caravanes Pliantes*



**Bermudes : Parthenon**  
**Batik : Corinthian**





# Solena®



**270 Kg** Poids à vide  
Weight (excl. baggage)  
Eigengewicht  
Leergewicht  
P.A.V.  
Peso propio



16.5 x 6.5-8

**400 Kg** Poids total en charge  
Maximum loaded weight  
Max. toelaatbaar gewicht  
Max. Gesamtgewicht  
P.A.P.C.  
Peso total

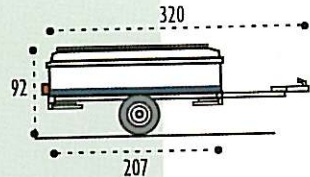
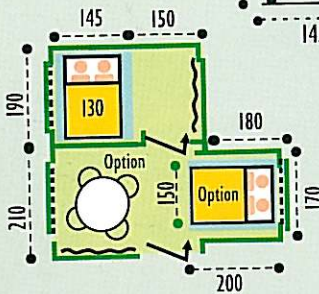
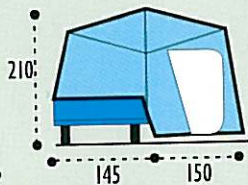

Option  
Optie  
Nach Wahl  
Optional  
Opcional  
Opzione

Avancée 210 cm  
Awning 210 cm  
Vorzelt 210 cm  
Voortent 210 cm  
Avance 210 cm  
Veranda 210 cm

Chambre annexe  
Bedroom annexe  
Schlafkabine  
Slaapcabine  
Habitacion  
Camera supplementare





Montage ultra rapide  
sans piquets.

Very quick erecting  
without pegs

Ongelovelijk snel  
op te zetten  
Zonder tenthammen

Sehr schneller  
Aufbau ohne  
Heringe.

Montaggio ultra  
rapido  
senza picchetti

Montaje ultra-rápido  
sin piquetas.

Option  
Tendelet 180 cm  
Optie  
Sun canopy 180 cm  
Nach Wahl  
Sonnensegel 180 cm  
Optional  
Zonnehuifel 180 cm  
Opcional  
Visera-foldo parasol 180 cm  
Opzione  
Tendalino 180 cm

# Solena®



Itinerant





# Escapade®



**270 Kg**  
 Poids à vide  
 Weight (excl. baggage)  
 Eigengewicht  
 Leergewicht  
 P.A.V.  
 Peso proprio



16,5 x 6,5-8

**400 Kg**  
 Poids total en charge  
 Maximum loaded weight  
 Max. toelaatbaar gewicht  
 Max. Gesamtgewicht  
 P.A.P.C.  
 Peso total

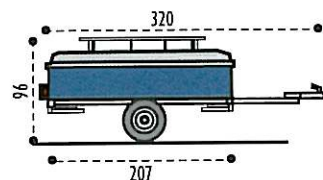
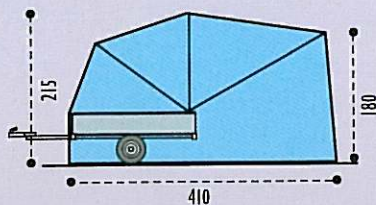
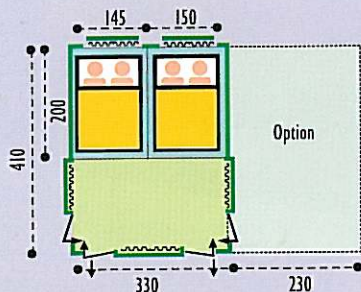

Option Auvent latéral  
 Optional Awning  
 Nach Wahl Voortent  
 Optional Abnehmbares vorzelt  
 Opzione Avance staccabile  
 Veranda staccabile  
 230 cm





# Escapade®

Option Tendelet,  
Optional Sun awning  
Nach Wahl Luifel  
Opcional Sonnenschutz  
Opzione Parasole  
Visera-parasol  
170 cm



RAGLET

Caramore Phantasia



# Quick Stop



**380 Kg**

Poids à vide  
Weight (excl. bagage)  
Eigengewicht  
Leergewicht  
P.A.V.  
Peso proprio



135 x 13

**495Kg - 650 kg (NL)**

Poids total en charge  
Maximum loaded weight  
Max. toelaatbaar gewicht  
Max. Gesamtgewicht  
P.A.P.C.  
Peso total

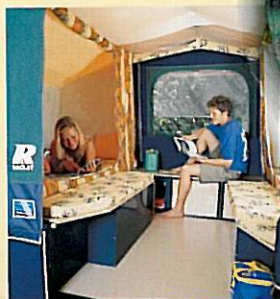

Annexe multifonction  
Storage Annexe  
Seitenanbau  
Berging cabine  
Anexo de colocacion  
Vano disimpegno

Option  
Optional  
Nach Wahl  
Opcional  
Opzione

Chambre annexe  
Bedroom annexe  
Schlafkabine  
Slaapcabine  
Habitation  
Camera supplementare

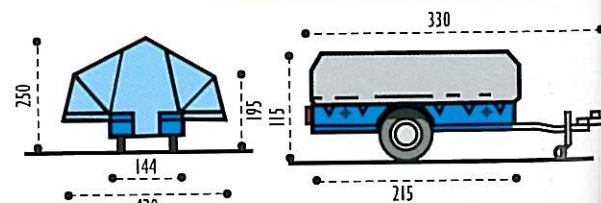
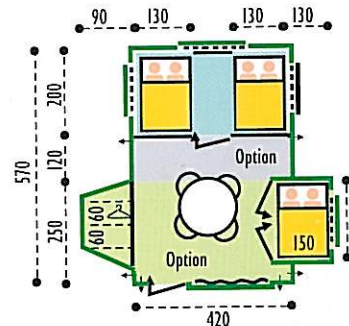



# Quick Stop



Montage ultra rapide  
sans piquets.

Very quick erecting  
without pegs.

Ongelovelijk snel  
op te zetten  
Zonder tenthaakjes

Sehr schneller  
Aufbau ohne  
Häklinge.

Montaggio ultra  
rapido  
senza picchetti.

Montaje ultra rápido  
sin piquetas



- Option Tendeler
- Optional Sun awning
- Nach Wahl Luft
- Optional Sonnenschutz
- Opzione Parasole
- Visera-parasol 160 cm



Caravaning Pleasure



# Globe Trotter®



**450 Kg**

Poids à vide  
Weight (excl. baggage)  
Eigengewicht  
Leergewicht  
P.A.V.  
Peso proprio



135 x 13

**495 kg / 650 kg NL**

Poids total en charge  
Maximum loaded weight  
Max. toelaatbaar gewicht  
Max. Gesamtgewicht  
P.A.P.C.  
Peso total

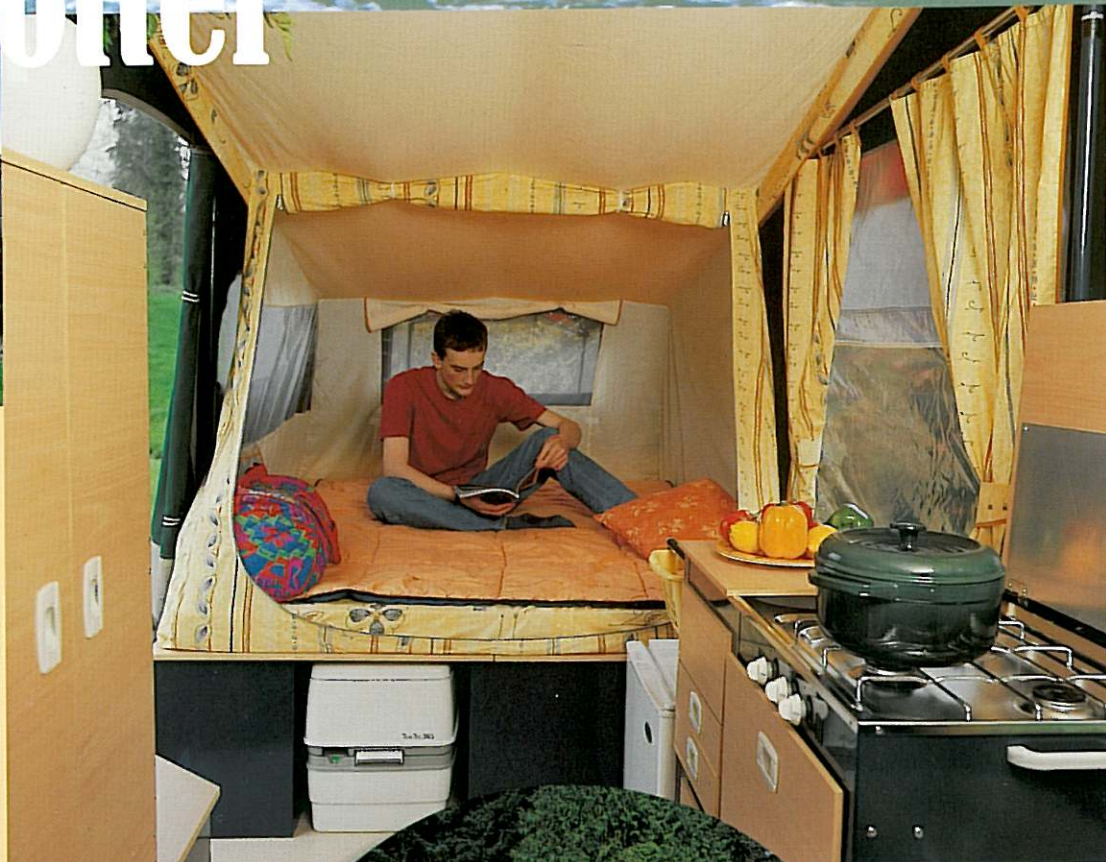

Option Pare-soleil.  
Optional Sun awning  
Nach Wahl Luifel  
Opcional Sonnenschutz  
Opzione Parasole  
Visera-parasol  
170 cm

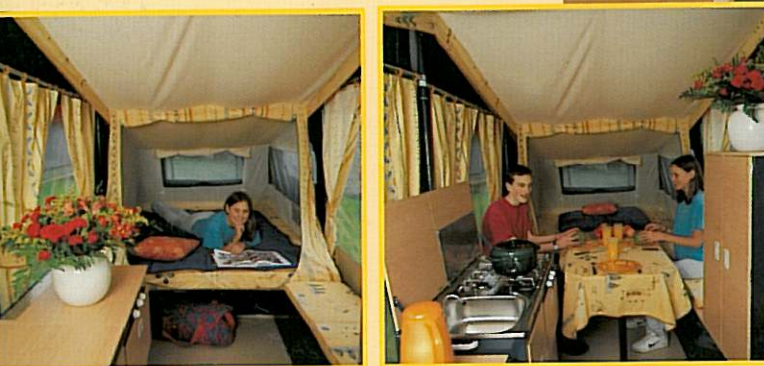
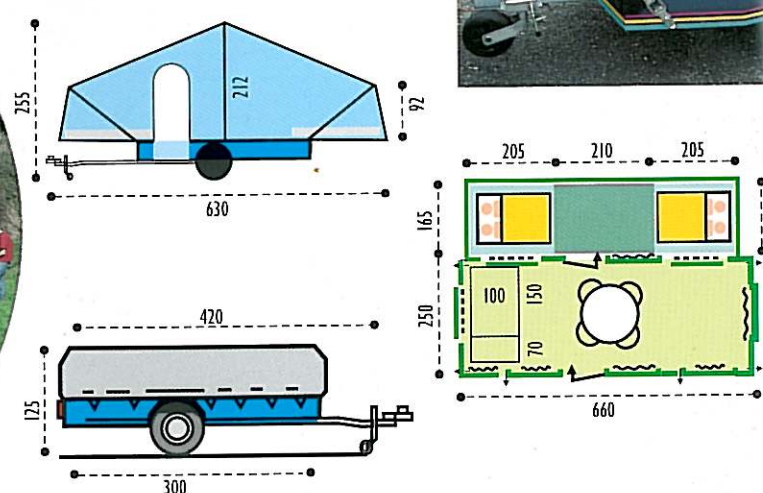
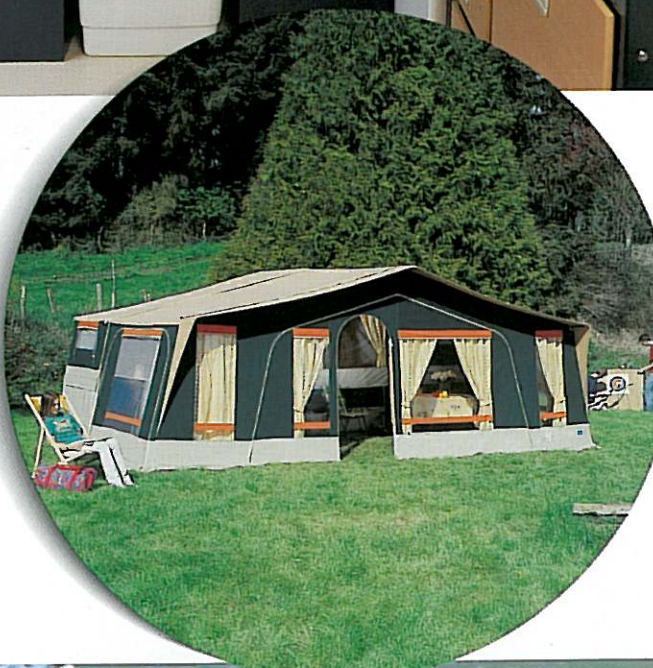

Option Avancée  
Optional Awning  
Nach Wahl Voortent  
Opcional Abnehmbares vorzelt  
Opzione Avance desmontable  
Veranda staccabile  
250 cm



# Globe Trotter®



Montage ultra rapide  
sans piquets.

Very quick erecting  
without pegs.

Ongelovelijk snel  
op te zetten  
Zonder tentharingen

Sehr schneller  
Aufbau ohne  
Häringe.

Montaggio ultra  
rapido  
senza picchetti.

Montaje ultra-rápido  
sin piquetas.



**RACLET**  
Caravanes Pliantes



Super Quick Stop



# Equipements et accessoires

**1** Berceaux de garage  
Storage brackets  
Kantelbeugels  
Kippvorrichtung  
Archi di remessagio  
Mensulas de estacionamiento

**2** Roue jockey / Jockey wheel  
Telescopisch neuswiel  
Bugrad / Ruota jockey  
Rueda jockey

**3** Essieu freiné,  
recul automatique  
Axle with brake  
Oplooprem met  
terugrijautomaat  
Achse mit Bremsvorrichtung  
und Rückfahrautomatik  
Assle con freno  
Eje con freno

**4** Berceaux de garage  
Up two sans roulettes  
Storage brackets  
Kantelbeugels  
Kippvorrichtung  
Archi di remessagio  
Mensulas de estacionamiento

**5** Galerie / Roof-rack  
Imperial / Gepäckträger  
Portebagagli / Baca

**6** Pare-soleil / Sun awning  
Luifel / Sonnenschutz  
Parasole / Visera-parasol

**7** Chambre 2 places adaptable  
sous plateau  
Under-bed inner tent  
Tweepersoons-ondertent  
Zusatzschlaf- oder Staukabinen  
Camera 2 posti adattabili sotto ripiano  
Cuarto de 2 puetos adaptables bajo repisa

Les équipements ainsi que les caractéristiques peuvent varier en fonction des pays. The fittings as well technical data can vary according to each country. Die Ausstattungen sowie die technischen Angaben können je nach Land variieren. De uitvoeringen evenals de technische opgaven kunnen per land verschillen. Los equipos y las características técnicas pueden cambiar de un país a otro. Le dotazioni e le caratteristiche tecniche potranno variare.

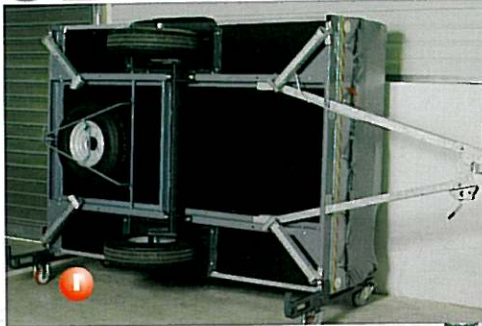

**8** Coffres sous banquettes  
Bench storage lockers  
Staukasten met veel bergruimte  
Staukästen unter Sitzflächen  
Bauletti sotto panchine  
Cofres bajo los asientos

**9** Table / Table / Tafel  
Tisch / Tavola / Mesa

**10** Aération chambre double volet  
Ventilated inner tents  
Goede ventilatie mogelijkheden  
Zimmerbelüftung-Doppelvorhänge  
Finestra camera sotto ripiano  
Ventilación habitaciones

**11** Meuble cuisine  
Kitchen unit  
Keukenblok  
Küchenblock  
Blocco cucina  
Bloque cocina



Coffre sur flèche  
Towbar storage box  
Disselbak  
Deichselkasten  
Porta frigo per timone  
Depósito timón

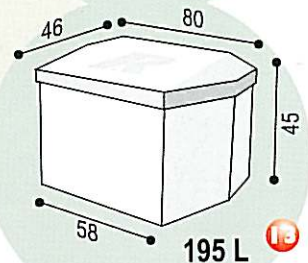
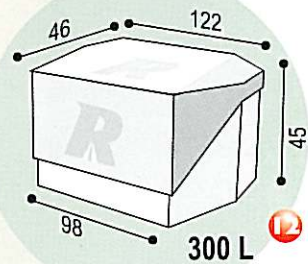



# Uptwo

## CHASSIS AMOVIBLE TRANSFORMABLE

Système exclusif - Brevet International

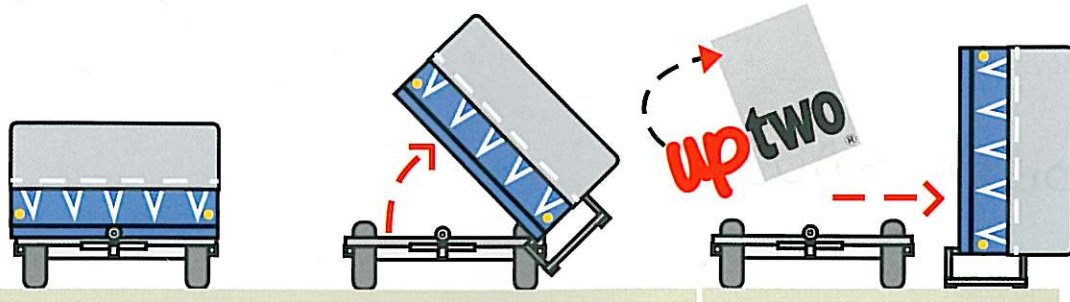

### REMOVABLE CHASSIS

Unique system  
International Patent

### VOUW WAGENBAK AFNEEMBAAR

Exclusief  
Gepatenteerd systeem

### WECHSELCHASSIS

Patentiertes system

### AMOVIBILE E TRASFORMABILE CASSONE

Sistema brevettato

### CARROCERIA SEPARABLE DEL CHASIS

Sistema esclusivo  
Patente mundial



# Carrosserie



### CARROSSERIE

Tôle acier électrozinguée, revêtement polyester.

Châssis galvanisé\*

Suspension : roues indépendantes sur barre de torsion caoutchouc

### BODYWORK

Electro zinc-treated sheet metal, epoxy painted finish

Galvanised chassis\*

suspension : independent wheels, rubberised torsion units

### WAGENBAK

Verzinkt en epoxy gelakt

Gegalvaniseerd chassis\*

Vering : onafhankelijke wielophanging, rubber geveerd

### KAROSSERIE

Elektrisch verzinkt Stahlblech mit Polyester-Ueberzug

Galvanisiertes Fahrwerk\*

Einzelradaufhängung mit gummigelagerter Torsionsstabfederung

### CASSONE

Lamiera acciaio elettrozincata, rivestimento poliester

Cassone galvanizzato\*

Sospensione : ruote indipendenti su aste di torsione in gomma

### CAJA

Chapa electro-zincada, revestimiento poliéster

Chasis galvanizado\*

Suspensión independiente sobre goma de torsión de caucho

(\*Sauf, except, behalve, auBer, eccetto, excepto Minto)



# Dépliage



## ARMA Clic®

### Armature télescopique

entièrement solidarisée :

ARMAclic est deux fois plus légère qu'une armature acier traditionnelle. Elle se déploie et se replie en un clin d'oeil. Le réglage est fiable et très simple grâce à un astucieux système de bagues. ARMAclic est en aluminium anodisé inaltérable diamètre 28 mm. Système breveté.

**Fully inter-connected** in dural it unfolds and re-folds again into one piece. International patents

**Parapluframe.** Gemakkelijk in en uit te vouwen aluminium voortent frame. Het parapluframe is zo eenvoudig, je hoeft niet meer te stoeien met stokken, want alles zit aan elkaar vast en is eenvoudig door één persoon op te zetten. Internationaal gepatenteerd.

**Aluminium-gestänge** in einem Stück. Patentiertes system

**Armaturo in alluminio** interamente unita. Modello brevettato

**Armodura aluminio** del avance, de uno sola pieza (opcional). Sistema patentado

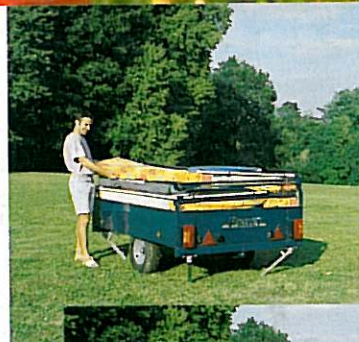

## Dépliage ultra rapide

Easy action erecting system

Fameus opzetsysteem

Automatischer Aufbau

Apertura automatica

Apertura automática



Notre catalogue ne peut être considéré comme contractuel. Nous nous réservons la possibilité d'apporter toutes modifications que nous jugeons utiles à nos produits.

Our catalogue cannot be considered as contractually binding. We reserve the right to make any modification we consider necessary to our products.

Deze folder mag niet als contractueel worden beschouwd. Raclet behoudt zich het recht voor om technische en commerciële verbeteringen door te voeren.

Unser katalog ist vertraglich nicht bindend. Wir behalten uns das Recht vor, jederzeit für uns nützliche Änderungen vorzunehmen.

Il nostro catalogo non può essere ritenuto contrattuale, ci riserviamo la possibilità di apportare ogni modifica da noi ritenuta utile ai nostri prodotti.

Nuestro catalogo ne puede estar considerado como caracter contractual. Nos reservamos la posibilidad de anadir toda modification que sea oportuna.



Caravanes Pliantes

Haut Eclair  
72600 Mamers - France  
Tél 02 43 31 12 30  
Fax 02 43 31 12 31  
<http://www.raclet.fr>

**LOISIRS**  
**Finance**

Le spécialiste du financement des caravanes, camping-cars, mobil-homes, équipements de loisirs chez votre distributeur.