

## Warranty

Lunars are famously well built and reliable, but for total peace of mind ALL Lunar Caravans are supplied with:

- A 6 year body shell integrity warranty
  - A 3 year manufacturers backed warranty (specific exclusions apply).
- (Subject to an annual service and inspection and excluding items subject to normal wear and tear).

Each Lunar model has been certified by the NATIONAL CARAVAN COUNCIL for compliance with stringent European Standards, British Standards AND the industry set Codes of Practice that specifically relate to health and safety issues.

The approvals process covers the testing and inspection of all critical areas of the product from fire safety, weights and dimensions through to gas, electrics and ventilation. In order to ensure Lunars continuing compliance with their stringent standards, the NCC also carry out unannounced spot inspections at the company's Preston factory.

Every caravan carries the 'NCC Approved Caravan' badge that gives you the peace of mind in the knowledge that your caravan is both fully legal AND safe.

*Special thanks to:*

### **Belfield Furnishings Group**

Tel: 0115 907 1834

Website: [www.belfieldfurnishings.co.uk](http://www.belfieldfurnishings.co.uk)

For the supply of all fixed bed dressings featured – to purchase any of these dressings please contact Belfield directly

### **Bowker BMW of Preston**

Tel: 01772 766070

Website: [www.bowkermotorgroup.com](http://www.bowkermotorgroup.com)

### **Design Fix**

Tel: 01772 687639

Website: [www.designfix.org.uk](http://www.designfix.org.uk)

For the staging and styling

### **Farington Lodge Hotel**

Tel: 01772 421321

Website: [www.classiclodges.co.uk](http://www.classiclodges.co.uk)

Your Authorised Lunar Dealer.

Updated Information.

# The LUNAR 2012 Caravan Collection



## Welcome to Lightweight Luxury



[www.lunarcaravans.com](http://www.lunarcaravans.com)

Sherdley Road, Lostock Hall, Preston, Lancashire PR5 5JF Email: [sales@lunarcaravans.com](mailto:sales@lunarcaravans.com)





## The LUNAR 2012 Caravan Collection

### More Indulgence and Less Weight

With specification beyond compare, the Lunar 2012 Caravan Collection beckons you to experience a more indulgent caravan with innovatively less weight.

The collection consists of 23 models across our Ariva, Quasar, Stellar, Lexon, Clubman and Delta ranges. Each of these models combines our passion for peerless craftsmanship and pioneering design throughout every detail.

With over 40 years expertise, this new collection offers the ultimate in strength, quality and durability at matchless low weights that are still up to 15% lighter than our rivals.

### A Home from Home

At Lunar, our caravan interiors mean more than just making the best possible use of space or creating practical features, it's about making you feel at home.

We have developed layouts that provide an airy and sophisticated feel to create the perfect space whether you are relaxing or entertaining. To deliver the very finest in comfort and luxury, our layouts are complemented by opulent furnishings and stylish specifications that have been inspired by the homeware and furnishings market.

### Discover the Difference

We work closely with our retailers to ensure we have a fantastic portfolio of our new collection for you to see and experience.

If you would like to discover the ultimate in lightweight luxury touring, you can find a local approved dealer at [www.lunarcaravans.com](http://www.lunarcaravans.com)

Our retailers will be delighted to discuss your touring requirements with you to ensure your lightweight luxury Lunar caravan exceeds your every expectation.

# Welcome to Lightweight Luxury

As a Lunar owner, we believe you deserve the very best in design, craftsmanship, quality and innovation. Our award winning team of highly skilled designers, engineers and craftsman are as passionate about creating a lightweight Lunar caravan as you are in owning one.

## Our Vision

Our design language is to combine the powerful techniques of 3 dimensional computer aided design with traditional caravan building skills. Every feature, every space is designed to provide you with optimum comfort, convenience and practicality.

The vision becomes reality with the use of high tech components and materials, sourced from only the finest suppliers in the industry, meticulously selected for their performance, strength and weight. The result is a distinctively superior caravan that radiates quality and performs with an impressive weight advantage of being up to 15% lighter than its rivals.

## Craftsmanship

Our team of craftsman bring luxury and utility to our beautifully crafted interiors. Featuring warm woods, sumptuous fabrics and elegant lighting, each model is fully equipped to create the ultimate living space whatever your tastes. We craft our exteriors to boast sophistication. Defined by sleek, smooth lines, attention to detail is key and reflects what is so reputedly known as Lunar quality.

## Peace of Mind

The safety of your family and caravan is our paramount concern. We are proud to design every Lunar with a range of leading innovations to ensure your caravan meets optimum levels of safety and security. We also work with suppliers who are dedicated to continual research and development.

## Green Thinking

The Lunar lightweight design delivers greater fuel economy, easier manoeuvrability and the option to choose a wider range of towing vehicle.

For the 2012 season, we have also focussed on generating energy saving benefits through our interiors. Each model has 100% LED internal lighting and a unique shower head that reduces water consumption by up to 20% while maintaining high pressure.

Caravan manufacturing produces many tonnes of waste each year. Our wood waste, which is normally destined for landfill, is now burnt in our Carbon Neutral Biomass Energy Heating System. This has drastically reduced the amount of waste that we send to landfill and the hot air generated is used to heat our factory.



# Award Winning Pedigree

The pleasure of owning a Lunar Caravan is underlined by a proud history in award winning design and craftsmanship.

For over 40 years our caravans have been claiming the most coveted awards for style, comfort, quality and innovation. We are truly honoured that our caravans are recognised year after year by prestigious organisations such as the Caravan Industry, the Caravan Owners Club, and the specialist caravan industry press to name but a few.

Developing award winning models requires the support of production excellence so we have invested in an array of new technology. From the multi-drill technology, to the five CNC (computer numerical control) machining centres, we strive to push our manufacturing boundaries.

In relation to our manufacturing, we are extremely proud to have won a Business Improvement Techniques award at the prestigious Yorkshire Productivity Awards 2011. The award was presented to our team following their implementation of very successful lean manufacturing techniques.



*Ariva – Small yet Amazingly Roomy  
Lightweight Obeche Wood  
Reducing Wood Waste*

*Delta TI – Sumptuous Leather Upholstery Option  
Proud Winners of a Business Improvement Techniques Award*

Lightweight Luxury from Lunar



## The LUNAR 2012 Ariva & Quasar Collection

### ***Stylish, Comfortable Lightweight Touring***

The new Ariva / Quasar range captures the true meaning of lightweight luxury. Styled with opulent new chestnut wood interiors, fresh new 'Tilla' furnishings and distinguished new features, this range provides style, comfort and specification. Simply choose between 8 innovative single axle models, ranging from 2 to 6 berth to suit families of all sizes.

As every centimetre in a caravan is precious, there are many functional and practical ideas behind our 2012 Ariva / Quasar enhancements. The new Sanyo Microwave has been lowered in height position where possible for much easier access. The new domestic styled kitchen locker doors have a modern edge but also provide excellent storage. The 100% LED lighting ensures a perfect light source for cooking or relaxing while also minimising power consumption. The new end-washroom shower cubicle has been designed to be more spacious while the high pressure 'Eco-Camel' shower head reduces water consumption, up to 20%. In our fixed bed models, we have used luxury pocket sprung mattresses to ensure the very best nights sleep.

With a sense of family adventure, the key to the Ariva / Quasars success is that all these luxury features are crafted into a range that also boasts low towing weights, enabling models to be towed by most typical family cars.

The multi-award winning Ariva is totally unique in its class. Our Ariva has the narrowest and one of the lightest bodies of its rivals while also being the most luxurious. With an MTPLM of under 1000kg, the Ariva's clever design makes this caravan feel incredibly spacious while being truly compact.

The new Quasar 494 is a short and very light 4 berth yet it cleverly boasts a comfortable lounge, a side dinette with bunk above, plenty of storage and a spacious end wash room.

The Ariva / Quasar range is perfect for families who enjoy the true touring pleasures of luxury, space and flexibility.

-   
**Ariva - 2 Berth**

---

-   
**Quasar 462 - 2 Berth**

---

-   
**Quasar 464 - 4 Berth**

---

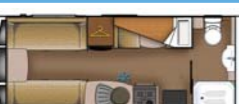
-   
**Quasar 494 - 4 Berth**

---

-   
**Quasar 534 - 4 Berth**

---

-   
**Quasar 544 - 4 Berth**

---

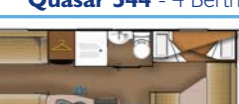
-   
**Quasar 546 - 6 Berth**

---

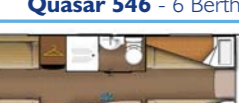
-   
**Quasar 556 - 6 Berth**





## Ariva & Quasar Additional Key Features

- **NEW** - Stylish Exterior Graphics and Colours
- AL-KO AKS Stabiliser
- LED Awning Light
- "Super Pitch" Water Connection Point
- **NEW** - Domestic Style Pivot Shower Door (End Bathroom Models)
- **NEW** - Shower with Dedicated Controls
- **NEW** - LED Shower Light
- **NEW** - Pull Cord or External Light Switch to all Bathrooms
- **NEW** - Offside Toilets in all Models (No Emptying Via Awning Side)
- Domestic Style Sliding Door/Handle to Bathrooms (Model Specific)
- **NEW** - Lightweight Freestanding Table
- **NEW** - Stylish Furniture Door Handles
- **NEW** - Luxury Pocket Sprung Mattress to all Fixed Bed Models
- Blinds and Fly Screens to all Windows
- **NEW** - LED Ceiling Lights
- **NEW** - LED Lighting under Kitchen Eye Level Lockers
- **NEW** - Chrome Wirework to Kitchen Lockers
- Aspire Separate Grill and 42L Oven - with Spark Ignition and Flame Failure Device
- 4 Burner Hob with 3 Gas and 1 Electric plate
- Laminated Sink Cover and Plastic Bowl
- Radio/CD/MP3 Player with 2 speakers



Under Bed Storage with External Access  
New 100% LED Lighting and Integrated Speakers  
New Laundry Basket  
Digital TV Connection Points

Radio/CD/MP3 Player  
New Contemporary Vanity Basin  
and Swan Head Tap

New Water Saving Eco-camel Shower Head  
Quasar 546 - Comfy Triple Bunks and a Children's Seating Area  
New Domestic Styled Shower with Dedicated Controls and Shelving



## The LUNAR 2012 Stellar & Lexon Collection

### ***Sophisticated, Luxurious Lightweight Touring***

The new Stellar / Lexon 2012 range has an enviable reputation for sophisticated style, comfort and space. The new 'Pamplona' furnishings provide a contemporary elegance and complement this ranges stunning new features. This breathtaking collection consists of 7 single axle models, ranging from 2 to 5 berth.

With a greater emphasis on luxury for 2012, the Stellar/Lexon range combines a high degree of functionality with a contemporary twist. A new exterior back panel adds sleek lines and highlights attention to detail. Inside you'll discover new interiors that project light, space and storage. Each restyled kitchen features beautifully crafted kitchen locker doors with frosted infills, a new high capacity black enamel circular sink and a new Thetford electronic fridge with LED display.

The Stellar delivers an unmatched level of spaciousness in an industry leading wide body, yet compact length. With a revised layout for 2012, the Stellar retains its generous living space while also offering an offside bathroom with a separate fully lined shower.

The Lexon range provides the Lunar owner with a new dimension of lightweight luxury. Highlights this season include the introduction of two exciting new models. The 2 berth Lexon 420 provides an extremely comfortable lounge area, high specification kitchen and luxurious end washroom, all complemented by an MTPLM of just 1150kg. The new Lexon 520, a unique 4 berth model, is perfect for entertaining and relaxing. Beyond the front lounge and kitchen you will find an extra wide dinette with bunk above which leads to a spacious end washroom. Following the popularity of the transverse island bed with our Lunar owners, the Lexon 560 now boasts this stylish feature in the models end bedroom.

The Stellar / Lexon collection provides superb touring comfort and luxury with weights that are the lowest in their class.





**Stellar** - 2 Berth



**Lexon 420** - 2 Berth



**Lexon 520** - 4 Berth



**Lexon 530** - 4 Berth



**Lexon 540** - 4 Berth



**Lexon 550** - 5 Berth



**Lexon 560** - 4 Berth



*New Anthracite Thetford Electronic Fridge, Aspire Oven/Grill with New Glass Lid and New Kitchen Locker Doors  
New Black Enamelled Sink and New Swan Head Tap  
Lexon 550 – 5 Berth Family Layout with Extra Wide Dinette*

*Lexon 550 – 5 Berth Layout with Double Bunks*

**LUNAR 2012 - Stellar & Lexon**



# Stellar & Lexon Additional Key Features

- **NEW** - Stylish Exterior Graphics and Colours
- **NEW** - Redesigned Full Height Back Panel with Integral Light Clusters
- Interior Headroom of 1960mm/6'5"
- Security Alarm
- Remote Control Fob to Control Alarm and Awning Light
- Heavy Duty Corner Steadies All Around
- External BBQ Point
- Natural Wood Framed Roof Locker Doors in "Chestnut"
- Large Heki Lux Skylight over Front Lounge
- Colour Matched Worktop Laminates in "Crystal" design
- **NEW** - Domestic Style Framed Kitchen Locker Door with Perspex Infill
- **NEW** - Thetford Electronic Fridge with LED Display in Anthracite
- **NEW** - Black Glass Lid to Cooker Top
- **NEW** - Black Enamel Circular Sink with Separate Drainer
- Radio/CD/MP3 Player
- External Shower/ "Super Pitch" Connection Points
- Bed Ventilation Boards (to improve airflow and reduce condensation)
- Low Voltage, Cool Touch, LED Spot lights
- Removable Shelving to Roof Lockers in Front Lounge Areas
- Mini Heki to Washrooms (Model Specific)



Large Heki over Front Lounge and Fixed Beds  
New Mirrored Vanity Area Complements the New  
Vanity Basin with Swan Head Tap

Heavy Duty Corner Steadies  
Chrome Grab Handles  
Lexon 550 – Space for all the Family

Lexon 530 – Double Bed with Great Access  
The Ultimate in Washroom Luxury  
Lexon 560 – Plush Transverse Bed Leads to a Great Space for Cooking



## The LUNAR 2012 Clubman & Delta Collection

### ***Indulgent, Sumptuous Lightweight Touring***

The Clubman / Delta 2012 collection is the ultimate lightweight luxury touring experience. This range has been designed as the perfect solution for those who love to combine the freedom of touring with sumptuous home comforts.

The range interiors blend stylishly and seamlessly together with new 'Naomi' fabrics, warm 'Chestnut' woods, elegantly curved cabinetry and new luxury pile carpet. With every feature so distinctively luxurious, the Clubman / Delta range delivers everything you would expect as a Lunar owner, and so much more. The stunning collection includes 5 single axle Clubman models and 3 twin axle Delta models that range from 2 to 5 berths.

At Lunar we are meticulous about every detail so the enhancements made to our Clubman/ Delta range radiate sophistication and innovation. The new kitchen locker doors with frosted infill are complemented with mood lighting for a designer feel finish. LED mood lights have also been added to the front lounge and bedroom to create a homely atmosphere.

Alongside the new larger shower and new hand basin, all end washrooms now feature a domestic wet central heating radiator with chrome towel rail above.

The new Delta FB is a flagship family model. This 5 berth layout features an enormous front lounge, extra wide dinette for family dining, large kitchen with great workspace, double wardrobe for ample storage, two 6'2" bunk beds and a spacious end washroom.

The Clubman / Delta collection is the envy of the touring field. Perfect for relaxing and entertaining, each model delivers indulgent home from home comforts. This collection is undoubtedly true Lunar pedigree at its finest.



**Clubman CK** - 2 Berth

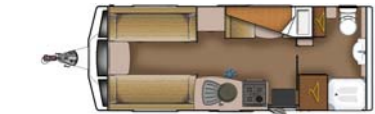

**Clubman ES** - 4 Berth



**Clubman SB** - 4 Berth



**Clubman SE** - 4 Berth



**Clubman SI** - 4 Berth



**Delta FB** - 5 Berth - Twin Axle

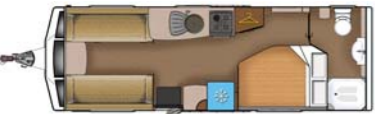

**Delta RS** - 4 Berth - Twin Axle



**Delta TI** - 4 Berth - Twin Axle





# Clubman & Delta Additional Key Features

- **NEW** - Stylish Exterior Graphics and Colours
- Phantom Tracker Complete with 12 months subscription
- AL-KO Secure Wheel Lock (2 on Delta Models)
- AL-KO Jack (Delta Models only)
- AL-KO ATC Anti-Snaking Device
- Underslung 40L Water Tank with Auto Switch Over (Delta Models only)
- Roof strength for Air-conditioning on Delta Models
- Alde Hydronic Wet Central Heating System on all Clubman and Delta Models
- **NEW** - Domestic Wet Central Heating Bathroom Radiator
- **NEW** - Towel Rail over Radiator on all models
- Control Panel with Water gauge (Delta only)
- Soft Roll Pleated Blinds to all Windows
- **NEW** - Low Voltage, Cool Touch, LED Mood Lights to Front Lounge
- **NEW** - Low Voltage, Cool Touch, LED Mood Lights to Bedrooms
- **NEW** - LED Light Inside all Wardrobes
- Low Level LED Night Time Courtesy Light
- 2 additional Speakers to Bedrooms
- **NEW** - LED Mood Lighting inside Kitchen Eye Level Lockers
- 180L Large Capacity Fridge / Freezer with LED Display (Delta Models Only)
- External Shower Connection Point
- "Super Pitch" Water Connection Point

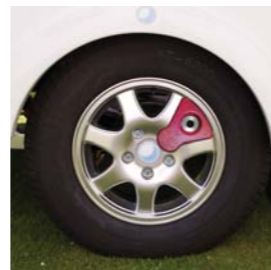
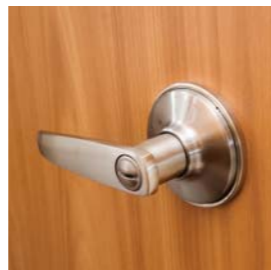

*Clubman SB - Inviting Large Single Beds and a Spacious End Washroom  
Clubman ES - Redesigned Washroom with New Wardrobe Storage*

*LED Spot Lights  
Domestic Style Doors, Handles and Locks  
AL-KO Secure Wheel Lock  
Award Winning Transverse Bed Layout*

*Take Sanctuary in the Elegant Washroom  
Luxurious Fixed Beds with New Pocket Sprung Mattresses  
New Domestic Styled Radiator and Chrome Towel Rail*

# 2012 LUNAR Range Features

## STANDARD FEATURES ON ALL MODELS ARIVA / QUASAR

### Safety and Security Features

- AL-KO-Secure Receiver
- CRIS Identity Etched onto Windows
- One Key fits ALL locks
- Smoke Alarm
- Unique Hidden Identity Tag
- AL-KO AKS Stabiliser

### Exterior Features

- Ariva Width 6'8" (2020mm)
- Quasar Width 7'1" (2160mm)
- Alloy Wheels
- AL-KO Galvanized Steel Chassis with One Action Easy Handbrake
- Double Glazed Windows with Blinds and Fly Screens
- 3 Opening Front Windows
- **NEW** - Stylish Exterior Graphics and Colours
- External Battery Locker
- External Storage Locker - Nearside with 240 Volt Socket (not Ariva)
- Fully adjustable Window Stays with Night Latch Ventilation Position
- Grade 111 Classification for Thermal Insulation & Heating
- Gas Locker to hold the following Bottle types:
  - 5kg Calor Patio Gas Bottle
  - 5kg BP Lightweight Gas Bottle
  - 7kg Steel Gas Cylinder
  - 10kg BP Lightweight Gas Bottle
- Gas Struts to Exterior Gas Locker
- Lunar Entrance Tray and Doormat
- Mud Flaps (not Ariva)
- Stylish 1 Piece Full Height Rear Panel (Ariva 3/4 Height)
- Stylish Rear Light Arrays
- Exterior Door with Long Window, Heavy Duty Door Handle and Lock

- Steel Spare Wheel
- Underslung AL-KO Spare Wheel Carrier to all Models (not Ariva)
- 13 Pin Connection Cable
- LED Awning Light

### Plumbing and Heating

- Isolation Taps for All Gas Appliances
- Pressurised Water System with Semi-rigid Piping
- Truma Gas/Electric Ducted Blown Air Heating
- Water - Truma Gas and Electric, Fully Plumbed-in
- External Shower Connection Point
- "Super Pitch" Water Connection Point

### Bathroom Features

- **NEW** - Larger Domestic Style Shower Cubicle (End Bathroom Models)
- **NEW** - Domestic Style Pivot Shower Door (End Bathroom Models)
- **NEW** - Shower with Dedicated Controls
- **NEW** - 'Eco Camel' Shower Head / Hose
- **NEW** - LED Shower Light
- **NEW** - Domestic Style Vanity Basin
- **NEW** - Domestic Style Swan Head Tap
- **NEW** - Mirrored Vanity Area with LED Lighting
- **NEW** - Laundry Basket (End Bathroom Models)
- **NEW** - Pull Cord or External Light Switch to all Bathrooms
- **NEW** - Offside Toilets in All Models (No Emptying Via Awning Side)
- C250 CWE Swivel Toilet - Electric Flush
- Mini Heki to Washrooms (Model Specific)
- Domestic Style Sliding Door/Handle to Bathrooms (Model Specific)
- Domestic Style Door with Handle and Lock to Bathrooms (Model Specific)
- 'Matisse' Toilet Wallboard (Model Specific)

### Interior Features

- Maximum Headroom 6'3" (1908mm)
- Waste Bin to Interior of Caravan Door
- Bed Ventilation Boards (to improve airflow and reduce condensation)
- Roll Out Slats for Easy Front Double Bed Make Up
- Blinds and Fly Screens to all Windows
- Blind and Fly Screen to Exterior Door
- **NEW** - Colour Matched Worktop Laminates in "Crystal" Design
- **NEW** - Contemporary Style Colour Edged Work surfaces in "Crystal" Design
- **NEW** - Lightweight Freestanding Table
- Front Chest of Drawers with Pull-out Coffee Table
- **NEW** - Stylish Furniture Door Handles
- **NEW** - Curved Post Formed Locker Doors in "Chestnut"
- Removable Shelving to Roof Lockers in Front Lounge Areas
- **NEW** - "Lunar Twist" Stain-Free Heavy Duty Carpet in "Fennel"
- 'Kanji' Ceiling and Wall Board
- Fully Sprung Seating
- **NEW** - Soft furnishings Scheme in "Tilla" Fabrics
- Aluminium Framed Lift up Front Beds
- Aluminium Framed Lift up Fixed Beds - model specific
- **NEW** - Luxury Pocket Sprung Mattress to All Fixed Bed Models
- Full Length Drop Down Flaps to Front Beds
- Midi Heki over Front Lounge
- Midi Heki over all Fixed Beds / Rear Lounge
- **NEW** - LED Ceiling Lights
- **NEW** - LED Corner Reading Lights
- Low Voltage, Cool Touch, LED Spot Lights

### Kitchen Features

- **NEW** - Sanyo Digital Microwave Oven
- **NEW** - Lower Eye Level Microwave Position (Model Specific)
- Thetford 112L Electronic Fridge with LED Display in Bronze (Ariva 97L)
- **NEW** - Domestic Style Swan Head Tap
- **NEW** - LED Lighting Under Kitchen Eye Level Lockers
- Aspire Separate Grill and 42L Oven - with Spark Ignition and Flame Failure Device
- 4 Burner Hob with 3 Gas and 1 Electric plate
- Bronze Enamel Circular Sink with Separate Drainer (not Ariva)
- Laminated Sink Cover and Plastic Bowl
- Integrated Stainless Steel Sink / Drainer (Ariva only)
- **NEW** - Chrome Wirework to Kitchen Lockers
- **NEW** - Domestic Style Framed Kitchen Locker Doors with Wooden Infil

### Electrical

- **NEW** - 100% LED Interior Lighting Throughout
- Single Easy Access Control Panel Housing All Main Controls
- 12 Volt Charger and Mains Transformer
- Colour Co-ordinated 230v Mains Sockets
- Mains Connection Lead (25 Metre)
- Mains Inlet with ELCB Protection

### Audio/Entertainment Features

- Radio/CD/MP3 Player with 2 Speakers
- Status 530-5 TV Aerial - Multi-Directional and Fully Adjustable
- 2-4 x TV points in all Models - all with Digital Connection
- Digital TV Connection Point Inside Battery Box

## FEATURES IN STELLAR / LEXON ABOVE STANDARD ARIVA / QUASAR

- Overall width 7'6" (2280mm)
- Interior Headroom of 1'960mm/6'5"
- Security Alarm
- Remote Control Fob to Control Alarm and Awning Light
- **NEW** - Redesigned Full Height Back Panel with Integral Light Clusters
- Heavy Duty Corner Steadies All Around
- Stainless Steel Grab Handles to Front and Rear Panels
- External BBQ Point
- **NEW** - Stylish Exterior Graphics and Colours
- **NEW** - "Lunar Twist" Stain-Free Heavy Duty Carpet in "Basil"
- **NEW** - Soft Furnishings Scheme in "Pamplona" Fabrics
- Natural Wood Framed Roof Locker Doors in "Chestnut"
- Large Heki Lux Skylight Over Front Lounge
- **NEW** - Domestic Style Framed Kitchen Locker Door with Perspex Infil
- **NEW** - Thetford Electronic Fridge with LED Display in Anthracite
- **NEW** - Black Glass Lid to Cooker Top
- **NEW** - Black Enamel Circular Sink with Separate Drainer

## FEATURES IN CLUBMAN / DELTA ABOVE STANDARD STELLAR / LEXON

- Phantom Tracker Complete with 12 Months Subscription
- AL-KO-Secure Wheel Lock (2 on Delta Models)
- AL-KO Jack (Delta Models only)
- AL-KO ATC Anti-Snaking Device
- **NEW** - Stylish Exterior Graphics and Colours
- Underslung 40L Water Tank with Auto Switch Over (Delta Models Only)
- Super Pitch Water Connection Point Complete with 15m Connection Hose
- External Shower Connection Point Complete with Hose and Shower Head
- Roof Strength for Air-conditioning on Delta Models
- Alde Hydronic Wet Central Heating System on All Clubman and Delta Models
- **NEW** - Domestic Wet Central Heating Bathroom Radiator
- **NEW** - Towel Rail Over Radiator on All Models
- Control Panel with Water Gauge (Delta Only)
- Soft Roll Pleated Blinds to All Windows
- **NEW** - "Countess" Luxury Pile Stain-Free Heavy Duty Carpet in "Honeycomb"
- **NEW** - Soft furnishings Scheme in "Naomi" Fabrics
- **NEW** - Low Voltage, Cool Touch, LED Mood Lights to Front Lounge
- **NEW** - Low Voltage, Cool Touch, LED Mood Lights to Bedrooms
- **NEW** - LED Light Inside All Wardrobes
- Low Level LED Night Time Courtesy Light
- 2 Additional Speakers to Bedrooms
- **NEW** - LED Mood Lighting inside Kitchen Eye Level Lockers
- **NEW** - Slide Out Chrome Baskets to Kitchen Base Units (Delta only)
- 180L Large Capacity Fridge / Freezer with LED Display (Delta Models Only)



# LUNAR's Heritage



### Touring For Over 40 Years

The Lunar story reflects 42 years of passion and pride for building caravans that are undoubtedly the best in lightweight luxury touring.

From humble beginnings, co-founders Brian Talbot and Ken Wilcock, named their caravan manufacturing business Lunar, following inspiration from the 1969 mission to land on the moon. They knew their caravans were exceptional but couldn't have imagined the size that Lunar has become today. From the flagship Clubman to the legendary little Ariva, through the years the Lunar ethos has remained constant: build lightweight high quality caravans with luxurious interiors.

Protecting our heritage and our future has always been paramount. When the company was sold to a European manufacturer in the 1990's it was a milestone when a management buyout, led by Chairman and CEO, Brian Mellor, was finalised in 2007.

Since the buyout, the innovation applied to both our caravans and our manufacturing has gone from strength to strength. We have made investments in a wide range of new manufacturing equipment and new design software technology. These advancements have become our trademark, setting our caravan collection apart from our rivals.

In March 2011, we were reunited with one of our very first models, a Lunar Saturn, that had toured with a family from Lancashire for over 40 years. This compact two berth was one of the first models we built. The family took delight in touring with this caravan all over the UK from 1969 right through to 2010.

Following a difficult decision in 2011 to finally retire from touring, the family contacted us to see if we could provide a final home for their Saturn which had become a real part of the family. We were absolutely thrilled with this opportunity as the Saturn signifies a Lunar heritage dedicated to quality and craftsmanship. We are extremely proud of our heritage and it is the drive behind our lightweight luxury innovations for the future.



# Fabric & Materials

### Soft Furnishing Combination Options

Lunar have carefully selected the standard soft furnishings to look great in each model range.

However for a small charge (and subject to availability) you may choose any soft furnishing combination from the 2012 range for your caravan. In addition to this there is a luxurious leather option available on selected models.

### Special L Shaped Layout Option

A popular choice amongst caravanners who like to relax in real comfort, Lunar's L shaped layout option offers a spacious seating area at the front of the caravan that can be converted into a large front double bed. In addition, this layout provides a long offside picture window and a neat floor cabinet – ideal for parking the TV on when you want to put your feet up!

The L shaped layout option is available as a special order (at an additional charge) on selected models.



Ariva / Quasar – 'Tilla'



Lexon / Stellar – 'Pamplona'



Leather Option  
(curtains/scatter cushions match the range standard fabric)



Clubman / Delta – 'Naomi'

# The LUNAR Owners Club

When you choose Lunar you have a great, exclusive opportunity to join the growing band of enthusiasts that enjoy all the special benefits of being a Lunar Owners Club member. As an Owners Club member you will receive regular information-packed newsletters with all the latest news on forthcoming events, letters from fellow members and the inside track on the new developments from Lunar Caravans themselves.

Every member is welcome at the Club's numerous exclusive rallies across the UK, you'll meet a host of new friends who share a common interest in enjoying caravanning in a Lunar. These seasoned veterans can also offer a wealth of knowledge and expertise to help you enjoy lightweight touring at its very best.

For further information and details on how to join please visit [www.lunarownersclub.net](http://www.lunarownersclub.net)



## LUNAR - Industry Partners

We work in close partnership with all of our suppliers to ensure that our caravans are fitted with the highest quality lightweight materials.

 <p><b>A Cut Above</b> Tel: 01524 35660 Web: <a href="http://www.carpets4.co.uk">www.carpets4.co.uk</a></p>	 <p><b>Alde International (UK) Ltd</b> Tel: 01933 677765 Web: <a href="http://www.alde.co.uk">www.alde.co.uk</a></p> <p><b>AL-KO Kober Ltd</b> Tel: 01926 818500 Web: <a href="http://www.al-ko.co.uk">www.al-ko.co.uk</a></p>	 <p><b>Belfield Furnishings Ltd</b> Tel: 01159 071700 Web: <a href="http://www.belfieldfurnishings.com">www.belfieldfurnishings.com</a></p>	 <p><b>Bridgewood UK</b> Tel: 01482646464 Web: <a href="http://www.bridgewooduk.com">www.bridgewooduk.com</a></p>	 <p><b>Caravan Components</b> Tel: 01482 308468 Web: <a href="http://www.caravan-components.co.uk">www.caravan-components.co.uk</a></p>
 <p><b>Decorative Panels Lamination Ltd</b> Tel: 01484 658341 Web: <a href="http://www.decorativepanels.co.uk">www.decorativepanels.co.uk</a></p>	 <p><b>Dometic Seitz GmbH</b> Tel: ++49-6294-9070 Web: <a href="http://www.dometic.de">www.dometic.de</a></p>	 <p><b>Ellbee Ltd</b> Tel: 0113 257 9711 Web: <a href="http://www.ellbee.co.uk">www.ellbee.co.uk</a></p>	 <p><b>Euramax Coated Products Ltd</b> Tel: 01536 400 800 Web: <a href="http://www.euramax.eu">www.euramax.eu</a></p>	 <p><b>International Timber</b> Tel: 01257 246820 - 01257 246812 01257 246810 Web: <a href="http://www.internationaltimber.com">www.internationaltimber.com</a></p>
 <p><b>Sole Suppliers of Graphics to Lunar Caravans</b></p> <p><b>Motique Plastics Ltd</b> Tel: 01925 767868 Web: <a href="http://www.motique.co.uk">www.motique.co.uk</a></p>	 <p><b>Phantom Ltd</b> Tel: 0845 130 3301 Web: <a href="http://www.phantom.uk.net">www.phantom.uk.net</a></p>	 <p><b>Plastoform</b> Tel: +386 7 38 44 200 Web: <a href="http://www.plastoform.eu">www.plastoform.eu</a></p>	 <p><b>Polyplastic</b> Web: <a href="http://www.polyplastic.nl">www.polyplastic.nl</a> <b>Miriad Products Ltd (UK Agent)</b> Web: <a href="http://www.miriad-products.com">www.miriad-products.com</a></p>	 <p><b>The Ultimate Exterior and Interior Protection for your Caravan</b> <i>Ensuring Your Cherished Lunar Caravan Will Look Best On Site</i></p> <p>Freephone: 0800 6127 825</p> <p><b>Supagard</b> ADVANCED TECHNOLOGY</p>
 <p><b>Starco GB</b> Tel: 01889 571000 Web: <a href="http://www.starco.com">www.starco.com</a></p>	 <p><b>Tecnoform S.p.A.</b> Tel: +39 051 3761111 Web: <a href="http://www.tecnoform.com">www.tecnoform.com</a></p>	 <p><b>Thetford Ltd</b> Tel: 01142738157 Web: <a href="http://www.thetford.eu">www.thetford.eu</a></p>	 <p><b>Truma (UK) Ltd</b> Tel: 01283 586050 Web: <a href="http://www.trumauk.com">www.trumauk.com</a></p>	<p>Lunar Caravans would like to thank all our industry partners - for details visit <a href="http://www.lunarcaravans.com">www.lunarcaravans.com</a></p>

